

Platinum Resistance Temperature Detector

MH 220

Mseries PRTDs are designed for large volume applications where long term stability, interchangeability and accuracy over a large temperature range are vital. Typical applications are Automotive, White goods, HVAC, Energy management, Medical and Industrial equipment.

Nominal Resistance R0	Tolerance DIN EN 60751 1996-07	Tolerance DIN EN 60751 2009-05	Order Number Plastic Bag
100 Ohm at 0°C	Class A	F 0.15	32 207 577
	Class B	F 0.3	32 207 420

The measuring point for the nominal resistance is defined at 8mm from the end of the sensor body.

Specification	DIN EN 60751 (according to IEC 751)	
Temperature range	-70°C to 600°C (continuous operation) Tolerance Class B: -70°C to +600°C Tolerance Class A: -50°C to +300°C	
Temperature coefficient	TC = 3850 ppm/K	
Leads	AuPd- wire	
Lead lengths (L)	10mm ±1mm	
Long-term stability	max. R ₀ -drift 0.04% after 1000h at 600°C	
Vibration resistance	at least 40g acceleration at 10 to 2000 Hz, depends on installation	
Shock resistance	at least 100g acceleration with 8ms half sine wave, depends on installation	
Environmental conditions	unhoused for dry environments only	
Insulation resistance	> 100 MΩ at 20°C; > 2 MΩ at 500°C	
Self heating	0.4 K/mW at 0°C	
Response time	water current (v= 0.4m/s):	t _{0,5} = 0.06s t _{0,9} = 0.20s
	air stream (v= 2m/s):	t _{0,5} = 3.0 s t _{0,9} = 13.0s
Measuring current	100Ω: 0.3 to 1.0mA (self heating has to be considered)	

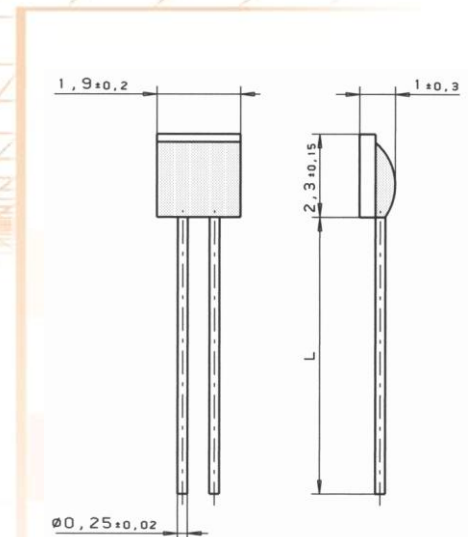

Note Other tolerances, values of resistance and wire lengths are available on request.

For brazing and soldering of the leads only brazing/solder alloys should be used which are specified for brazing/soldering to gold alloys.

We reserve the right to make alterations and technical data printed. All technical data serves as a guideline and does not guarantee particular properties to any products.

Heraeus Sensor Technology GmbH, Reinhard- Heraeus- Ring 23, 63801 Kleinostheim, Germany
Phone: +49 (0) 6181/35-8098, Fax: +49 (0)6181/35-8101, E-Mail: info.HSND@Heraeus.com Web: www.heraeus-sensor-technology.com